



**John
BOOS**
Since 1887

ITEM #: _____ QTY: _____
 MODEL #: _____
 PROJECT NAME: _____

081820

3601 S. Banker St. Effingham, IL 62401 • P.O. BOX 609 • Ph: (888) 431-2667 • Fax: (800) 433-2667

"ABPR-S" ALUMINUM MOBILE PAN RACKS - SIDE LOAD

FEATURES:

- 6063 ALUMINUM 1" SQUARE TUBING
- BOLTED CROSS RAILS
- 3" SPACING - 20 PAN CAPACITY
- 5" CASTERS

CONSTRUCTION:

- RACK: 6063 ALUMINUM; MIG WELDED.

MATERIAL:

- 6063 ALUMINUM



STANDARD MOBILE PAN RACK- SQUARE TOP DESIGN

MODEL #	QTY
ABPR-1820-3KDS	



NESTING RACKS

STANDARD MOBILE PAN RACK- ROUND TOP DESIGN

MODEL #	QTY
ABPR-1820-RKDS	

NESTED MOBILE PAN RACK- SQUARE TOP DESIGN

MODEL #	QTY
ABPR-1820-ZNS	

DETAILED SPECIFICATIONS

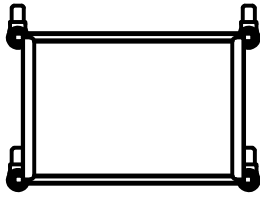

KNOCK DOWN
BOLT TOGETHER
CONSTRUCTION

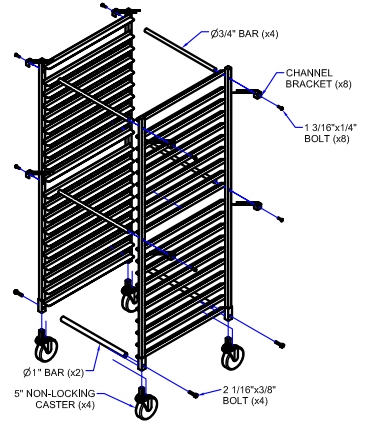
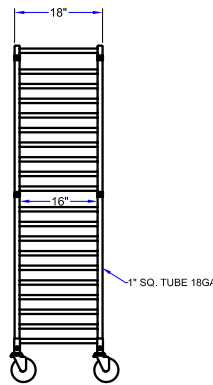
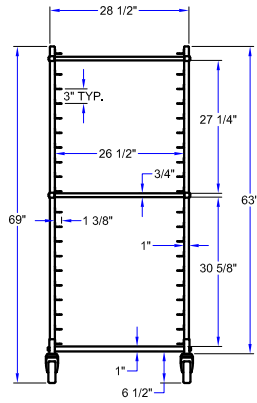

STANDARD MOBILE PAN RACK- SQUARE TOP DESIGN

MODEL #	LENGTH	WIDTH	HEIGHT	WT. (LBS)	WT. LIMIT/RACK(LBS)	WT. LIMIT/PAN (LBS)
ABPR-1820-3KDS	28-1/2"	18"	69"	30	200	10

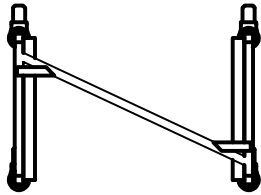

KNOCK DOWN
BOLT TOGETHER
CONSTRUCTION

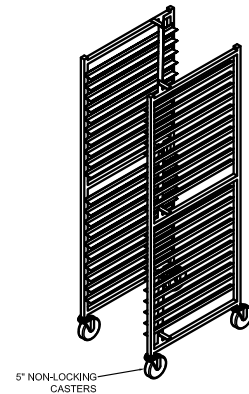
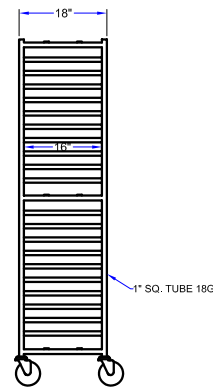
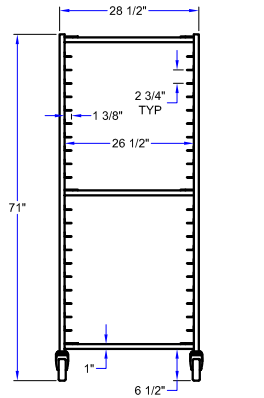

NESTED MOBILE PAN RACK- SQUARE TOP DESIGN

MODEL #	LENGTH	WIDTH	HEIGHT	WT. (LBS)	WT. LIMIT/RACK(LBS)	WT. LIMIT/PAN (LBS)
ABPR-1820-ZNS	28-1/2"	18"	71"	30	300	10



FULLY WELDED SET-UP
CONSTRUCTION

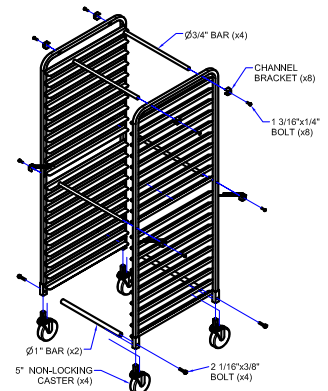
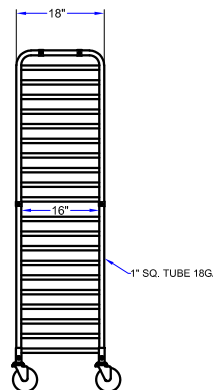
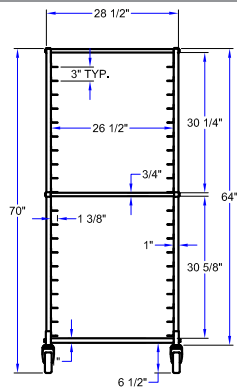

STANDARD MOBILE PAN RACK- ROUND TOP DESIGN

MODEL #	LENGTH	WIDTH	HEIGHT	WT. (LBS)	WT. LIMIT/RACK(LBS)	WT. LIMIT/PAN (LBS)
ABPR-1820-RKDS	28-1/2"	18"	70"	30	200	15

SOME UNITS SHIP UNASSEMBLED FOR REDUCED SHIPPING COST. ALL DIMENSIONS ARE TYPICAL. TOLERANCE +/- .500"

John Boos & Co. is constantly engaged in a program of improving products and therefore reserves the right to change specifications without prior notice.



3601 S. Banker St. • Effingham, IL 62401 • PO BOX 609 • quotes@johnboos.com

081820



www.johnboos.com

117